

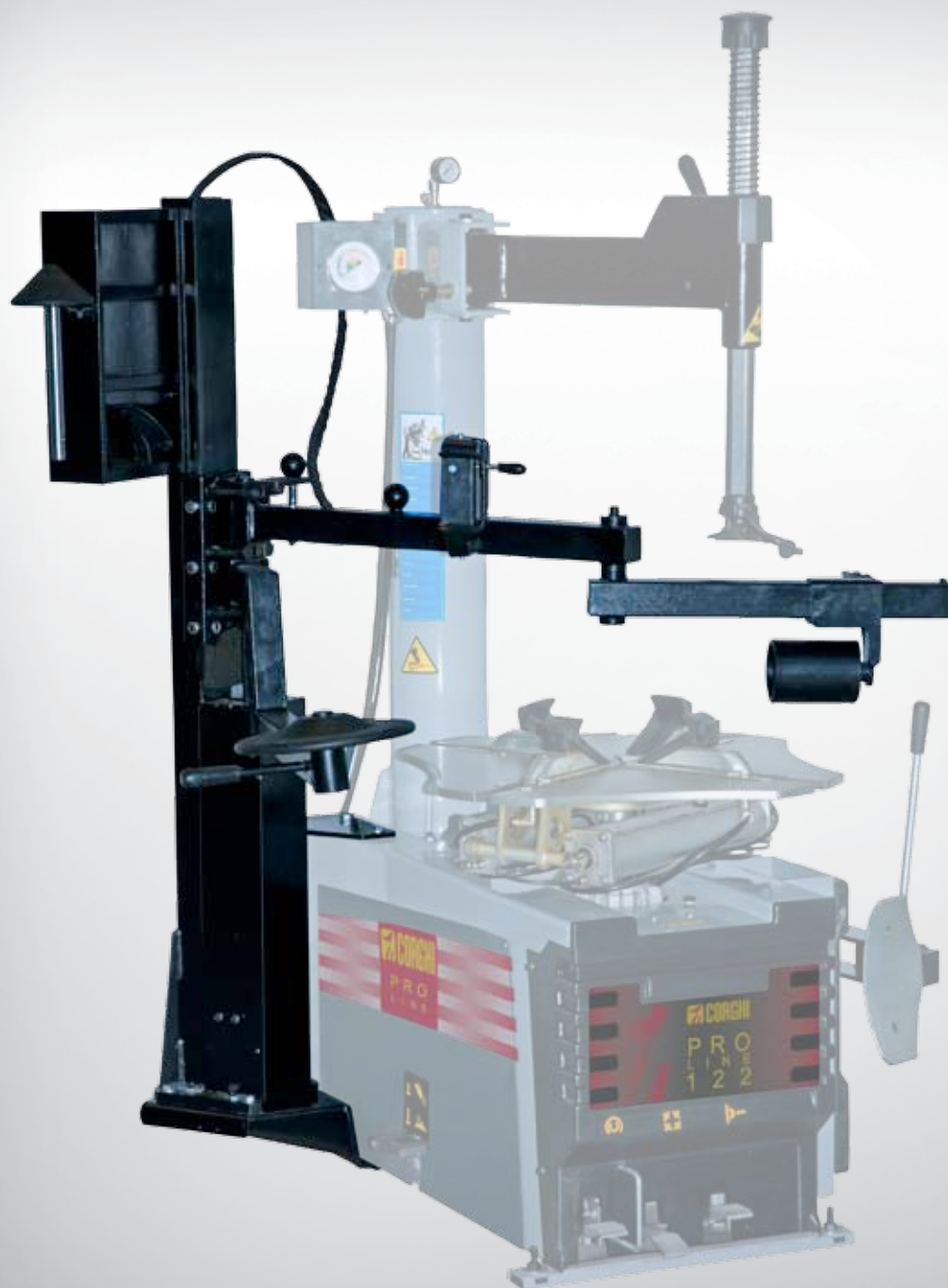

HELPER SX3



 **Dispositivo multifunzionale universale**
per agevolare montaggio e smontaggio dello pneumatico

 **Universal multifunctional device**
for facilitating tyre mounting and demounting

 **Universelle Mehrzweckvorrichtung**
zur Erleichterung der Reifenmontage und demontage



Il dispositivo **HELPER SX3** è un comodo e funzionale Helper appositamente studiato per rendere le operazioni di montaggio e smontaggio più veloci precise e sicure. È in grado di lavorare su tutte le tipologie di pneumatici, super ribassati, run-flat e cerchi in lega leggera. Applicabile su tutta la gamma di smontagomme vettura Proline con braccio a bandiera.



The **HELPER SX3** is a practical and functional Helper device specifically designed to make mounting and demounting operations quicker, more precise and safer. Capable of working on all types of tyre - including ultra low profile and run flat tyres - and light alloy wheel rims. It can be fitted to the whole Proline range of swing arm car tyre changers.



Die Vorrichtung **HELPER SX3** ist eine bequeme und funktionelle Helper, die eigens entwickelt wurde, um die Montage- und Demontearbeiten schneller, genauer und sicherer zu machen. Erhältlich in zwei Ausführungen, die an allen Reifenarten wie Superniederquerschnittreifen, Runflat-Reifen und Leichtmetallfelgen arbeiten können. Auf der gesamten Baureihe der Pkw-Reifenmontiermaschinen Proline mit Schwenkarm verwendbar.



● **RULLO PREMITALLONE.** Facilita le operazioni di smontaggio e montaggio primo tallone, mantenendo il tallone nel canale del cerchio. Agevola la fase di smontaggio del secondo tallone. ● **BEAD PRESSING ROLLER.** Facilitates demounting and mounting of first bead by keeping the bead within the rim well. Facilitates demounting of second bead. ● **WULSTNIEDERHALTERROLL.** Vereinfacht die Arbeiten für die Demontage und Montage des ersten Wulsts, indem der Wulst im Felgenbett gehalten wird. Erleichtert die Demontage des zweiten Wulsts.



● Il **DISCO GRANDE** consente il sollevamento dello pneumatico e il distacco del tallone inferiore. ● **The LARGE DISC** lifts the tyre and detaches the lower bead. ● Die **GROSSE SCHEIBE** gestattet das Anheben des Reifens und das Lösen des unteren Wulsts.



● Il rullo premitallone mantiene il tallone dello pneumatico nel canale del cerchio. Il **CONO PREMICERCHIO** favorisce il bloccaggio del cerchio sull'autocentrante in presenza di pneumatici rigidi. ● **The bead pressing roller** keeps the tyre bead within the rim well. A **WHEEL PRESSER CONE** facilitates clamping of the wheel onto the turntable when working with particularly rigid tyres. ● Die **Wulstniederhalterrolle** hält den Reifenwulst im Felgenbett. Der **FELGENNIEDERHALTERKONUS** unterstützt das Einspannen der Felge auf dem Spannteller bei steifen Reifen.



DATI TECNICI

campo di lavoro	10" ÷ 24"
altezza massima ruota	13"
forza di pressione su utensili	7000 N
pressione di esercizio	8-10 bar
peso	70 Kg

TECHNICAL DATA

working range	10" ÷ 24"
maximum wheel height	13"
press force on tools	7000 N
operating pressure	8-10 bar
weight	70 Kg

TECHNISCHE DATEN

Einsatzbereich	10" ÷ 24"
Max. Radhöhe	13"
Druckkraft an den Werkzeugen	7000 N
Betriebsdruck	8-10 bar
Gewicht	70 Kg

DIMENSIONI DI INGOMBRO - OVERALL DIMENSIONS - ABMESSUNGEN HELPER SX3

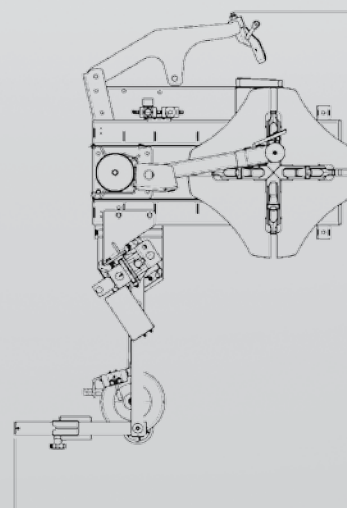

2095

1388

Fotografie, caratteristiche ed i dati tecnici non sono vincolanti, possono subire modifiche senza preavviso. The manufacturer reserves the right to modify the features of its products at any time. Les photographes, les descriptions et les données techniques ne sont pas contraignantes. Le fabricant se réserve le droit d'apporter des modifications sans préavis. Fotografieren, Eigenschaften und technische Daten sind nicht bindend und können ohne Vorankündigung geändert werden. Las fotografías, las características y los datos técnicos no son vinculantes. La empresa se reserva el derecho de modificarlos en cualquier momento. As fotografias, as características e os dados técnicos não são vinculantes, podem ser modificados sem prévio aviso. Code: DP6000501A - 01/2018

Per aiutare il pianeta ottimizzando il consumo di carta, i nostri cataloghi sono consultabili sul sito www.corgi.com. Una stampa responsabile aiuta a preservare l'ambiente. To protect the planet and reduce paper usage, our catalogues are viewable online at the website www.corgi.com. Printing responsibly contributes to saving the environment.

