

HELPER SX1



Dispositivo premitallone per agevolare il montaggio/smontaggio dello pneumatico



Bead pressing device to facilitating tyre mounting/demounting



Wulstniederhaltevorrichtung für die leichtere Montage/Demontage des Reifens



Il dispositivo **HELPER SX1** è un comodo e funzionale Helper appositamente studiato per rendere le operazioni di montaggio e smontaggio più veloci precise e sicure.

È in grado di lavorare su tutte le tipologie di pneumatici, super ribassati, run-flat e cerchi in lega leggera.



The **HELPER SX1** is a practical and functional Helper device specifically designed to make mounting and demounting operations quicker, more precise and safer.

Capable of working on all types of tyre - including ultra low profile and run flat tyres - and light alloy wheel rims.



Die Vorrichtung **HELPER SX1** ist eine bequeme und funktionelle Helper, die eigens entwickelt wurde, um die Montage- und Demontearbeiten schneller, genauer und sicherer zu machen.

Erhältlich in zwei Ausführungen, die an allen Reifenarten wie Superniederquerschnittreifen, Runflat-Reifen und Leichtmetallfelgen arbeiten können.



● **LA FUNZIONALITÀ DEL DISPOSITIVO**, regolabile in altezza, si limita alla sola fase di pressione del tallone dello pneumatico dall'alto. Applicabile su tutta la gamma di smontagomme vettura Proline con braccio a bandiera.

● **THE FUNCTIONALITY OF THE DEVICE**, adjustable in height, is limited to only the phase of the tyre bead pressing from above. It can be fitted to the whole Proline range of swing arm car tyre changers.

● Die **FUNKTION** der in der Höhe einstellbaren Vorrichtung beschränkt sich nur auf die Phase, in der der Reifenwulst von oben gedrückt wird. Auf der gesamten Baureihe der Pkw-Reifenmontiermaschinen Proline mit Schwenkarm verwendbar.

● Il **PRESSORE** mantiene il tallone dello pneumatico nel canale del cerchio: in fase di smontaggio, posizionato dalla parte opposta alla torretta e abbassato sullo pneumatico fino a portare il tallone in corrispondenza del canale del cerchio, consente al tallone stesso di non essere in eccessiva tensione e di salire più agevolmente sulla torretta.

● A **DEPRESSOR** keeps the tyre bead within the rim well: positioned opposite the tools head when dismounting and it's pushed onto the tyre until the bead reaches the well of the rim; this ensures that the bead is not excessively tight and allows it to slip more easily onto the tools head.

● Der **NIEDERHALTER** hält den Reifenwulst im Felgenbett: bei der Demontage steht er auf der gegenüberliegenden Seite des Montagekopfs und ist auf den Reifen abgesenkt, so dass der Wulst bis in Höhe des Felgenbetts gebracht wird, wodurch seine übermäßige Spannung vermieden wird und er leichter auf den Montagekopf gleiten kann.



DATI TECNICI

campo di lavoro	10" ÷ 24"
altezza massima ruota	13"
forza di pressione su utensili	165 kg
pressione di esercizio	8-10 bar
peso	20 Kg

TECHNICAL DATA

working range	10" ÷ 24"
maximum wheel height	13"
press force on tools	165 kg
operating pressure	8-10 bar
weight	20 Kg

TECHNISCHE DATEN

Einsatzbereich	10" ÷ 24"
Max. Radhöhe	13"
Druckkraft an den Werkzeugen	165 kg
Betriebsdruck	8-10 bar
Gewicht	20 Kg

DIMENSIONI DI INGOMBRO - OVERALL DIMENSIONS - ABMESSUNGEN HELPER SX1

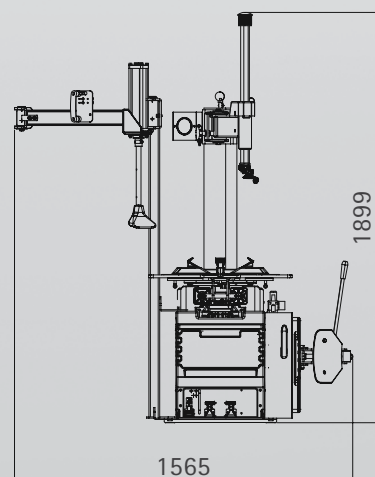

Fotografie, caratteristiche ed i dati tecnici non sono vincolanti, possono subire modifiche senza preavviso. The manufacturer reserves the right to modify the features of its products at any time. Les photographes, les descriptions et les données techniques ne sont pas contraignantes. Le fabricant se réserve le droit d'apporter des modifications sans préavis. Fotografieren, Eigenschaften und technische Daten sind nicht bindend und können ohne Vorankündigung geändert werden. Las fotografías, las características y los datos técnicos no son vinculantes. La empresa se reserva el derecho de modificarlos en cualquier momento. As fotografias, as características e os dados técnicos não são vinculantes, podem ser modificados sem prévio aviso. Code DP6000563A - 01/2018

Per aiutare il pianeta ottimizzando il consumo di carta, i nostri cataloghi sono consultabili sul sito www.corghi.com. Una stampa responsabile aiuta a preservare l'ambiente. To protect the planet and reduce paper usage, our catalogues are viewable online at the website www.corghi.com. Printing responsibly contributes to saving the environment.

