



Ravaglioli

COMPANY WITH
QUALITY SYSTEM
CERTIFIED BY DNV GL
= ISO 9001 =



Stivo



COMPLETAMENTE SENZA LEVA
COMPLETELY LEVERLESS
KOMPLETT HEBELLOS
COMPLÈTEMENT SANS LEVIER
TOTALMENTE SIN PALANCA

SMONTAGOMME SENZA LEVA 

LEVERLESS TYRE CHANGERS 

REIFENMONTIERGERÄTE OHNE MONTIERHEBEL 

DEMONTE-PNEUS SANS LEVIER 

DESMONTADORAS SIN PALANCA 

G

8645

8641

G

8246



G8641ID.24
+ PLUS83H helper
+ G800A119 disc



Slivo



**UTENSILE
SENZA LEVA
BREVETTATO**

Si inserisce tra pneumatico/cerchio e aggrappa il tallone sollevandolo progressivamente senza l'ausilio della leva alzatalloni.

**OUTIL
SANS LEVIER
BREVETÉ**

S'engage entre le pneumatique et la jante, et agrippe le talon en le soulevant progressivement sans l'aide de leviers décolle-talon.

**PATENTED
LEVER-FREE
TOOL**

Fits between the tyre and rim and takes hold of the bead, gradually lifting it without the aid of bead-lifter levers.

**ÛTIL SIN
DESMONTABLE
PATENTADO**

Se introduce entre el neumático/llanta y sujeta el talón elevándolo de forma progresiva sin la ayuda de palancas-separadores de talones.

**LEVER-FREE-
MONTAGEKOPF,
PATENTIERT**

Wird zwischen Reifen/ Felge eingeführt und spannt den Wulst durch progressives Heben ohne Montierenden.



1



2



3



L'esclusiva geometria di lavoro SLIVO permette la presa del tallone inferiore senza l'utilizzo del dispositivo PLUS.

The exclusive SLIVO working movement allows to catch the lower bead with no use of the PLUS device.

Die exklusive SLIVO-Arbeitsweise ermöglicht die untere Wulst ohne Einsatz des PLUS-Hilsmontagearm zu demontieren.

The système exclusif SLIVO permet la prise du talon inférieur même sans l'utilisation du système PLUS.

La exclusiva geometría de trabajo SLIVO facilita el agarre del talón inferior sin el utilizzo del brazo de ayuda PLUS.



1



2



3

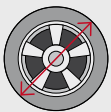

1143 mm (45")



431 mm (17")

		IN	OUT
G8645V.30	2 SPEED	12"-32"	10"-30"
G8645V.26		12"-28,5"	10"-26"
G8645V.22		13"-24,5"	11"-22"
G8645V.20		12"-22,5"	10"-20"
G8645D.30	VARIABLE SPEED	12"-32"	10"-30"
G8645D.26		12"-28,5"	10"-26"
G8645D.22		13"-24,5"	11"-22"
G8645D.20		12"-22,5"	10"-20"

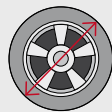

1050 mm (41")



381 mm (15")

		IN	OUT
G8641V.24	2 SPEED	12"-26,5"	10"-24"
G8641V.22		13"-24,5"	11"-22"
G8641V.20		12"-22,5"	10"-20"
G8641D.24	VARIABLE SPEED	12"-26,5"	10"-24"
G8641D.22		13"-24,5"	11"-22"
G8641D.20		12"-22,5"	10"-20"



V-VERSIONS

DOUBLE SPEED

D-VERSIONS

0-16 INVE MOTOR
 RPM VARIABLE SPEED

Il telaio di tipo largo e rinforzato garantisce estrema rigidità alla struttura e stabilità al mandrino. Il montaggio del riduttore fra due piastre di acciaio impedisce qualsiasi flessione.

The frame is large and reinforced, to grant the utmost rigidity to the structure and chucking table. The gear box is installed between two steel plates, to avoid flexion during operation.

Das breite und verstärkte Gehäuse garantiert eine grosse Steifigkeit der Struktur und Stabilität des Spanntisches. Der Einbau des Getriebes zwischen zwei Stahlplatten verhindert jegliche Biegung.

Le châssis large et renforcé garanti une grande rigidité à la structure et stabilité au plateau. Le montage du réducteur entre deux plaques en acier empêche toute flexion.

El chasis de tipo ancho y reforzado garantiza una extrema rigidez y estabilidad del plato. El montaje del reductor entre dos planchas de acero impide cualquier flexión.

Stallonatore

- Apertura regolabile in 2 posizioni per operare sempre con massima rapidità.
- Cilindro zincato a doppio effetto.

Bead breaker

- The bead breaker opening can be adjusted to work with extreme rapidity.
- Galvanised cylinder with double operation.

Abdrücker

- Verstellbare Öffnung des Abdrückers für ein rasches arbeiten.
- Mit verzinktem Kolben und doppelwirkend.

Decolle-pneu

- L'ouverture du décolle-pneus est réglable, pour garantir grande vitesse de travail.
- Cylindre zingué, à effet double.

Destalonador

- Abertura ajustable para trabajar siempre con la máxima rapidez.
- Cilindro cincado, de simple efecto.



Mandrino autocentrante

- Doppio senso di rotazione
- Elevata coppia torcente
- Elevata forza di serraggio (due pistoni)

Self-centring chuck

- Two-way rotation
- High torque
- High clamping force (two pistons)

Selbstzentrierende Spannvorrichtung

- Doppelte Drehrichtung
- Hohes Drehmoment
- Hohe Spannkraft (zwei Antriebszylinder)

Mandrin autocentreur

- Double sens de rotation
- Couple de torsion élevé
- Force de serrage élevée (deux vérins)

Mandril autocentrador

- Doble sentido de rotación
- Elevado par de torsión
- Elevada fuerza de fijación (dos pistones)



10"-20" / 11"-22"
 Mandrino standard.
 Standard chucking table.
 Standard Spanntisch
 Plateau standard
 Plato estándar



10" - 24" / 10" - 26" / 10" - 30"
 Mandrino riposizionabile a due posizioni.
 Chucking table with adjustable positioning of clamps (2 slots).
 Spanntisch mit in zwei Positionen einstellbaren Klauen
 Plateau à double positionnement
 Plato de dos posiciones.

OPTIONS

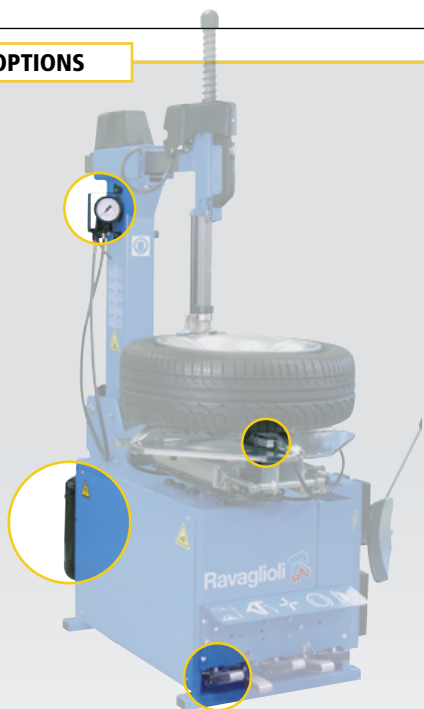

I-TYPE = BEAD-SEATER (TUBELESS INFLATOR)

Versioni con dispositivo di gonfiaggio pneumatici tubeless incorporato. Il dispositivo è azionato da un unico comando a pedale a due posizioni.

Models with tubeless tyre inflation system. The device is activated by a single pedal command with two positions

Versionen mit eingebauter Tubeless-Reifenfüllanlage. Die Vorrichtung wird über ein einziges Steuerpedal mit 2 Positionen betätigt.

Versions avec dispositif de gonflage tubeless incorporé. Le dispositif est actionné par une pédale de commande unique, à deux positions.

Versiones con dispositivo para inflar los neumáticos sin cámara incluido. Dispositivo accionado por un único mando de pedal con 2 posiciones.



SWING TYPE - SEMIAUTOMATIC

G8246D - variable speed
G8246V - two speed

OPTIONS



G800A98 → 20" - 22"
G800A6 → 24" - 26" - 30"
(4 x kit)



G800A8 (2 x kit)



G800A11

DATI TECNICI	TECHNICAL DATA	TECHN. SPEZIFIKATIONEN	DONNEES TECHNIQUES	DATOS TÉCNICOS	G8641V.20 G8641D.22 G8645V.20 G8645D.20	G8641V.22 G8641D.22 G8645V.22 G8645D.22	G8641V.24 G8641D.24	G8645V.26 G8645D.26	G8645V.30 G8645D.30
Motore	Motor	Drehstrommotor	Moteur	Motor	0,8/1,1 kW - 230/400V (50Hz) - 3ph (V version) 0,75 kW - 200/265V (50-60Hz) - 1ph (D version)				
Velocità di rotazione mandrino (giri/min)	Chuck rotation speed (rev./min)	Sperrvorrichtungs-Drehgeschwindigkeit (U./min.)	Vitesse de rotation du mandrin (tours/min.)	Velocidad de rotación mandrill (rev./min.)	6,5-13 rpm (V version) / 0-16 rpm (D version)				
Coppia max al mandrino	Max. torque to chuck	Max. Sperrvorrichtungs-Drehmoment	Couple max. au mandrin	Par máx al mandril	1200 Nm				
Bloccaggio dall'esterno	External clamping	Aussenspannung	Blocage extérieur	Bloqueo exterior	10"-20"	11"-22"	10"-24"	10"-24"	10"-30"
Bloccaggio dall'interno	Internal clamping	Innenspannung	Blocage intérieur	Bloqueo interior	12"-22,5"	13"-24,5"	12"-26,5"	12"-28,5"	12"-32"
Campo lavoro utensile	Tool working span	Arbeitsbereich des Montagekopfes	Capacité de travail	Campo de trabajo del util	8"-24" (G8641)		8"-32" (G8645)		
Diametro max pneumatico	Max. tyre diameter	Max. Reifendurchmesser	Diamètre max. du pneu	Diámetro máx neumático	1050 mm (41") (G8641)		1143 mm (45") (G8645)		
Larghezza max cerchio	Max. rim width	Max. Abdrückeröffnung	Largeur max. de la jante	Anchura máx llanta	381 mm (15") (G8641)		431 mm (17") (G8645)		
Forza stallonatore a 12 bar	Bead breaker cylinder power at 12 bar	Kraft des Abdrückvorrichtungszylinders: 12 bar	Force du cylindre décolle-pneus à 12 bars	Fuerza del cilindro destalonador de 12 bar	3600 kg (8000 lbs)				



Ravaglioli S.p.A.

40037 Sasso Marconi
Fraz. Pontecchio M.
P.O.B. 1690 - Bologna - Italia
Tel. +39 - 051 - 6781511
Fax +39 - 051 - 846349
rav@ravaglioli.com
www.ravaglioli.com

RAV France

4, Rue Longue Raie
ZAC de la Tremblaie
91220 Le Plessis Pâté
Tel. 01.60.86.88.16
Fax 01.60.86.82.04
rav@ravfrance.fr

Ravaglioli Deutschland

Kirchenpoint 22
85354 Freising
Tel. 08165-646956
Fax 08165-646958
ravd@ravaglioli.com

RAV Equipment UK LTD

Prince Albert House
20 King Street
Maidenhead, SL6 1DT
Tel. 020-76286832
Fax 020-76286833
ravuk@ravaglioli.com

RAV en Belgique

Nederlandstalig
Tel. 0498-162016
Fax 016-781025
Zone Francophone
Tel. 0498-163016
Fax +32 78 055 030

RAV Equipos España S.L.U.

Avenida Europa 17
Pol. Ind. de Constanti
Tarragona 43120
Tel. 977 524525
Tel. 0498-163016
Fax 977 524532
ravequipos@ravaglioli.e.telefonica.net

Le caratteristiche tecniche e gli allestimenti presentati in questo prospetto possono subire variazioni. Le immagini riprodotte non sono vincolanti.

Technical data and composition presented in this catalogue may vary. Pictures reproduced are only indicative.

Die techn. Daten und die Ausrüstungen, die in diesem Prospekt enthalten sind, können Änderungen erfahren. Deshalb sind die Abbildungen unverbindlich.

Les caractéristiques techniques et les compositions présentées dans ce prospectus peuvent subir des variations. Les images reproduites n'ont qu'une valeur indicative.

Las características técnicas y las composiciones ilustradas en este folleto pueden sufrir variaciones. Las imágenes propuestas son solamente indicativas.

DRN30U (4)

