

**GRU IDRAULICHE
A CARRELLO**

TROLLEY HYDRAULIC CRANES
GRUES HYDRAULIQUES A CHARIOT
FAHRBARE HYDRAULIKKRÄNE



ART. 134

TRACCIATO TECNICO COSTRUTTIVO

- Lo stelo rettificato e cromato garantisce un'alta affidabilità nel tempo.
- Braccio allungabile in quattro posizioni di lavoro.
- Ruote posteriori girevoli per la massima manovrabilità.
- Gancio girevole a 360°.
- Dotata di tiranti laterali.
- Valvola di protezione contro i sovraccarichi incorporata.
- Comando di discesa a velocità controllata.
- Pompa idraulica ad una velocità (131 - 132).
- Pompa idraulica a due velocità (133 - 134).
- Dotata di ruote in gomma (131 - 133).
- Dotata di ruote in gomma e nylon (132 - 134).

TECHNICAL AND STRUCTURAL LAY-OUT

- Ground chrome-plated rod for top reliability over time.
- Extendable arm in 4 working positions.
- Revolving rear wheels to move it easily.
- 360° revolving hook.
- Lateral tie-rods.
- Safety valve to avoid any possible overload.
- Descent control device with a controlled speed.
- One speed hydraulic pump (131 - 132).
- Two speed hydraulic pump (133 - 134).
- Rubber wheels (131 - 133).
- Rubber and nylon wheels (132 - 134).





RELEVÉ TECHNIQUE

- Vérin en acier spécial, rectifié et chromé, robuste et résistant.
- Flèche extensible: 4 positions de travail possibles.
- Roues arrière pivotantes pour faciliter les déplacements.
- Crochet pivotant à 360°.
- Tirants latéraux.
- Soupape de sécurité anti-surchage.
- Commande de descente à vitesse contrôlée.
- Pompe hydraulique à une vitesse (131 - 132).
- Pompe hydraulique à deux vitesses (133 - 134).
- Roues en caoutchouc (131 - 133).
- Roues en caoutchouc et nylon (132 - 134).

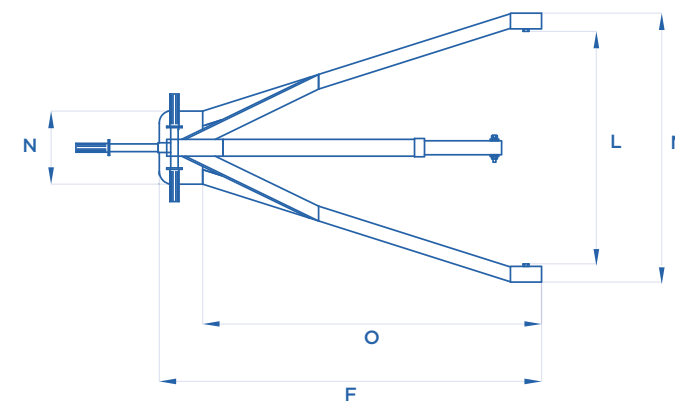
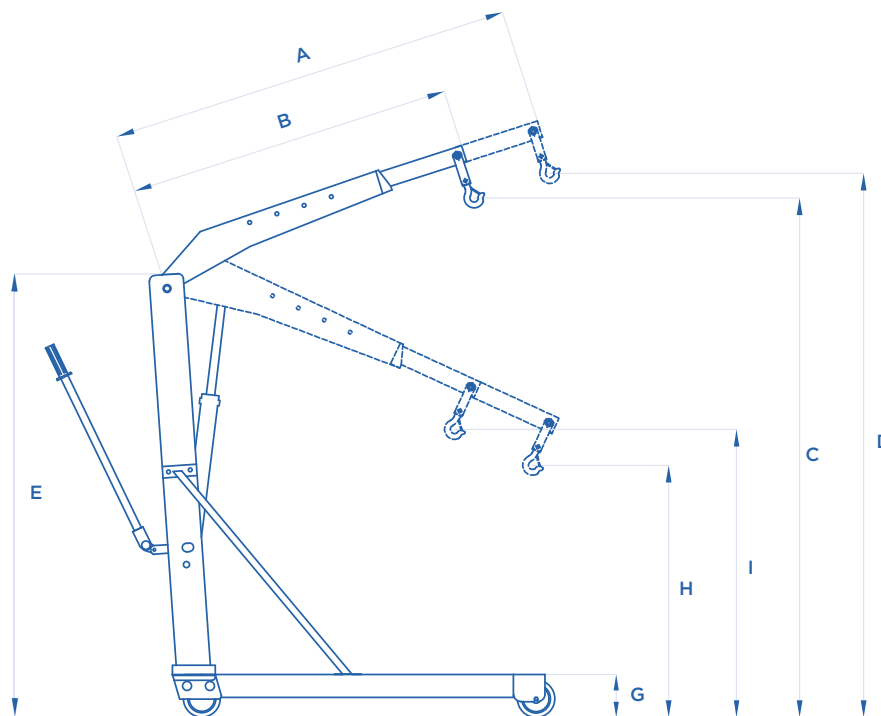
TECHNISCHE UND KONSTRUKTIVE ANGABEN

- Verchromte und schleifende Kolben, der eine große Zuverlässigkeit im Laufe der Zeit garantiert.
- Ausziehbarer Arm in vier Arbeitspositionen.
- Mit drehbaren Hinterrädern, um die maximale Wendigkeit zu sichern.
- 360° drehbare Haken.
- Mit seitlichen Zugöse.
- Angebaut Überlastventil gegen jeder Überlastung.
- Abstiegskontrolle mit einer kontrollierten Geschwindigkeit.
- Einstufige hydraulische Pumpe (131 - 132).
- Zweistufige hydraulische Pumpe (133 - 134).
- Mit Gummirädern (131 - 133).
- Mit Gummi- und Nylonrädern (132 - 134).



ART.				
131 • 133	500 kg	400 kg	250 kg	150 kg
132 • 134	1000 Kg	800 Kg	500 Kg	300 Kg

ART.		A mm	B mm	C mm	D mm	E mm	F mm	G mm	H mm	I mm	L mm	M mm	N mm	O mm	
131	500 Kg	1315	1015	2130	2355	1560	1295	160	435	660	785	900	600	1140	75
132	1000 Kg	1540	1250	2390	2670	1720	1530	180	470	670	955	1075	745	1360	110
133	500 Kg	1315	1015	2130	2355	1560	1295	160	435	660	785	900	600	1140	75
134	1000 Kg	1540	1250	2390	2670	1720	1530	180	470	670	955	1075	745	1360	110



ART. SL/15

TRACCIATO TECNICO COSTRUTTIVO

- Lo stelo rettificato e cromato garantisce un'alta affidabilità nel tempo.
- Braccio allungabile in quattro posizioni di lavoro.
- Ruote posteriori girevoli per la massima manovrabilità.
- Gancio girevole a 360°.
- Dotata di tiranti laterali.
- Valvola di protezione contro i sovraccarichi incorporata.
- Comando di discesa a velocità controllata.
- Pompa idraulica a due velocità.
- Dotata di ruote in poliuretano (SL/15 - 20 - 30).
- Dotata di ruote in nylon (SL/15E - 20E - 30E).

TECHNICAL AND STRUCTURAL LAY-OUT

- Ground chrome-plated rod for top reliability over time.
- Extendable arm in 4 working positions.
- Revolving rear wheels to move it easily.
- 360° revolving hook.
- Lateral tie-rods.
- Safety valve to avoid any possible overload.
- Descent control device with a controlled speed.
- Two-speed hydraulic pump.
- Polyurethane wheels (SL/15 - 20 - 30).
- Nylon wheels (SL/15E - 20E - 30E).





RELEVÉ TECHNIQUE

- Vérin en acier spécial, rectifié et chromé, robuste et résistant.
- Flèche extensible: 4 positions de travail possibles.
- Roues arrière pivotantes pour faciliter les déplacements.
- Crochet pivotant à 360°.
- Tirants latéraux.
- Commande de descente à vitesse contrôlée.
- Pompe hydraulique à deux vitesses.
- Roues en polyuréthane (SL/15 - 20 - 30).
- Roues en nylon (SL/15E - 20E - 30E).

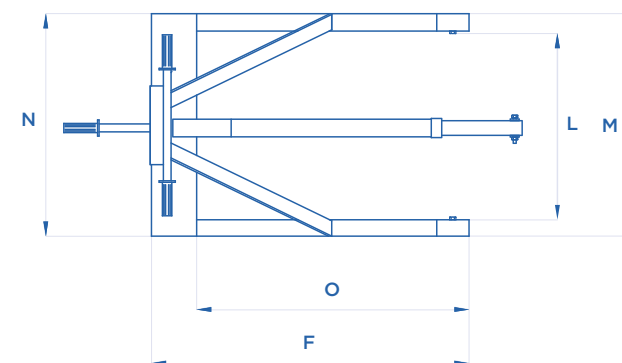
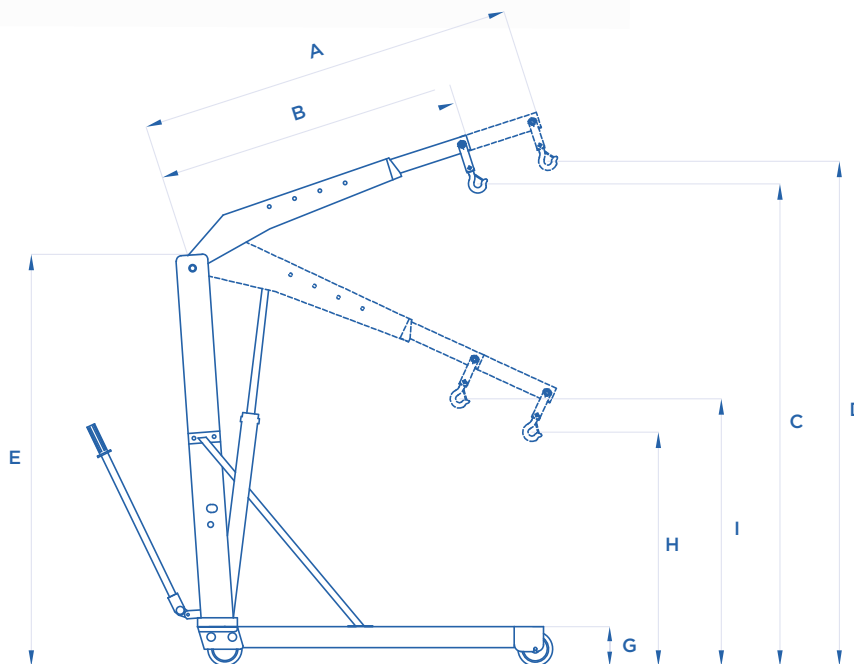
TECHNISCHE UND KONSTRUKTIVE ANGABEN

- Verchromte und schleifende Kolben, der eine große Zuverlässigkeit im Laufe der Zeit garantiert.
- Ausziehbarer Arm in vier Arbeitspositionen.
- Mit drehbaren Hinterrädern, um die maximale Wendigkeit zu sichern.
- 360° drehbare Haken.
- Mit seitlichen Zugöse.
- Angebaut Überlastventil gegen jeder Überlastung.
- Abstiegskontrolle mit einer kontrollierten Geschwindigkeit.
- Zweistufige hydraulische Pumpe.
- Mit Polyurethanrädern (SL/15 - 20 - 30).
- Mit Nylonrädern (SL/15E - 20E - 30E).



ART.				
SL/15	1500 kg	1200 kg	800 kg	500 kg
SL/20	2000 Kg	1500 Kg	1000 Kg	600 Kg
SL/30	3000 Kg	2400 Kg	1850 Kg	1300 Kg
SL/15E	1500 Kg	1200 Kg	800 Kg	500 Kg
SL/20E	2000 Kg	1500 Kg	1000 Kg	600 Kg
SL/30E	3000 Kg	2400 Kg	1850 Kg	1300 Kg

ART.		A mm	B mm	C mm	D mm	E mm	F mm	G mm	H mm	I mm	L mm	M mm	N mm	O mm	
SL/15 SL/15E	1500 Kg	1815	1370	2470	2750	1865	1690	195	310	630	830	1015	1000	1450	190
SL/20 SL/20E	2000 Kg	1910	1460	2780	3110	1990	1910	215	315	645	940	1120	1100	1640	235
SL/30 SL/30E	3000 Kg	2280	1790	3300	3730	2150	2270	265	510	780	1170	1420	1400	1910	480



TRACCIATO TECNICO COSTRUTTIVO

- Lo stelo rettificato e cromato garantisce un'alta affidabilità nel tempo.
- Braccio allungabile in quattro posizioni di lavoro.
- Ruote posteriori girevoli per la massima manovrabilità.
- Gancio girevole a 360°.
- Valvola di protezione contro i sovraccarichi incorporata.
- Comando di discesa a velocità controllata.
- Pompa idraulica a due velocità.
- Dotata di ruote in gomma (135).
- Dotata di ruote in gomma e poliuretano (136).
- Dotata di ruote in poliuretano (137 - 138 - 138/A).

TECHNICAL AND STRUCTURAL LAY-OUT

- Ground chrome-plated rod for top reliability over time.
- Extendable arm in 4 working positions.
- Revolving rear wheels to move it easily.
- 360° revolving hook.
- Safety valve to avoid any possible overload.
- Descent control device with a controlled speed.
- Two speed hydraulic pump.
- Rubber wheels (135).
- Rubber and polyurethane wheels (136).
- Polyurethane wheels (137 - 138 - 138/A).





RELEVÉ TECHNIQUE

- Vérin en acier spécial, rectifié et chromé, robuste et résistant.
- Flèche extensible: 4 positions de travail possibles.
- Roues arrière pivotantes pour faciliter les déplacements.
- Crochet pivotant à 360°.
- Soupape de sécurité anti-surcharge.
- Commande de descente à vitesse contrôlée.
- Pompe hydraulique à deux vitesses.
- Roues en caoutchouc (135).
- Roues en caoutchouc et polyuréthane (136).
- Roues en polyuréthane (137 - 138 - 138/A).

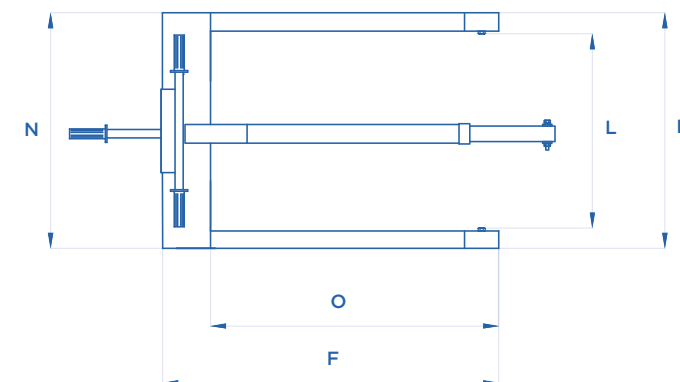
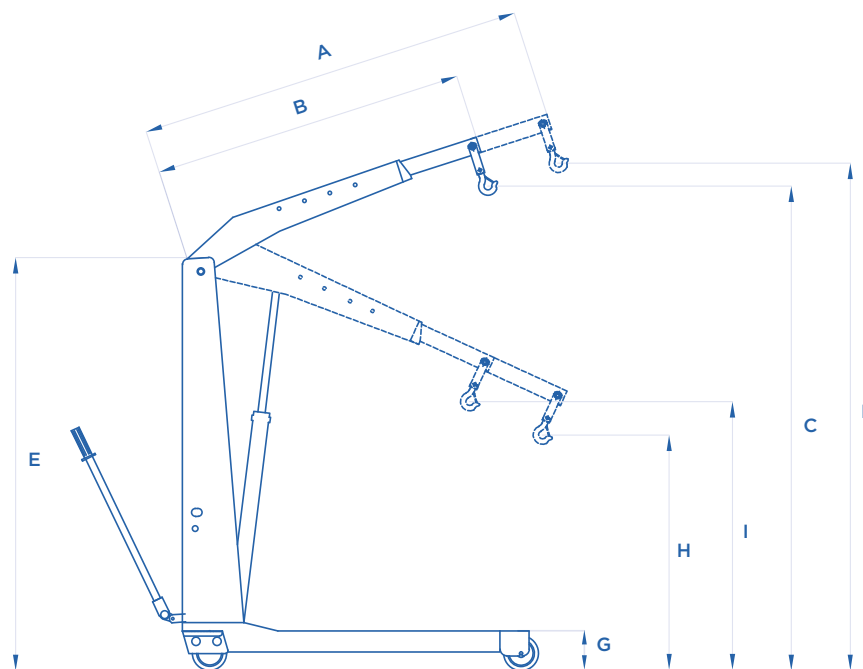
TECHNISCHE UND KONSTRUKTIVE ANGABEN

- Verchromte und schleifende Kolben, der eine große Zuverlässigkeit im Laufe der Zeit garantiert.
- Ausziehbarer Arm in vier Arbeitspositionen.
- Mit drehbaren Hinterrädern, um die maximale Wendigkeit zu sichern.
- 360° drehbare Haken.
- Angebaut Überlastventil gegen jeder Überlastung.
- Abstiegskontrolle mit einer kontrollierten Geschwindigkeit.
- Zweistufige hydraulische Pumpe.
- Mit Gummirädern (135).
- Mit Gummi und Polyurethanrädern (136).
- Mit Polyurethanrädern (137 - 138 - 138/A).



ART.				
135	500 Kg	400 kg	250 kg	150 kg
136	1000 Kg	800 Kg	500 Kg	300 Kg
137	1500 Kg	1200 Kg	800 Kg	500 Kg
138	2000 Kg	1500 Kg	1000 Kg	600 Kg
138/A	2500 Kg	2000 Kg	1500 Kg	1000 Kg

ART.		A mm	B mm	C mm	D mm	E mm	F mm	G mm	H mm	I mm	L mm	M mm	N mm	O mm	
135	500 Kg	1315	1010	2260	2490	1700	1370	155	520	745	650	805	800	1075	102
136	1000 Kg	1550	1250	2485	2695	1830	1520	165	560	760	790	960	960	1195	150
137	1500 Kg	1825	1370	2680	3010	1935	1810	185	310	650	960	1145	1140	1415	250
138	2000 Kg	1910	1460	2900	3300	2055	1915	213	510	795	1150	1350	1340	1480	315
138/A	2500 Kg	2010	1565	3020	3390	2085	2085	230	460	760	1180	1405	1390	1610	360

**HEAVY
DUTY**



ART. 222

TRACCIATO TECNICO COSTRUTTIVO

- Lo stelo rettificato e cromato garantisce un'alta affidabilità nel tempo.
- Braccio allungabile in quattro posizioni di lavoro.
- Timone di manovra posteriore e ruote di grandi dimensioni garantiscono ottima manovrabilità.
- Gancio girevole a 360°.
- Valvola di protezione contro i sovraccarichi incorporata.
- Comando di discesa a velocità controllata.
- Pompa idraulica a due velocità.
- Dotata di ruote in poliuretano.

TECHNICAL AND STRUCTURAL LAY-OUT

- Ground chrome-plated rod for top reliability over time.
- Extendable arm in 4 working positions.
- Rear rudder and big wheels to move it easily.
- 360° revolving hook.
- Safety valve to avoid any possible overload.
- Descent control device with a controlled speed.
- Two speed hydraulic pump.
- Polyurethane wheels.

RELEVÉ TECHNIQUE

- Vérin en acier spécial, rectifié et chromé, robuste et résistant.
- Flèche extensible : 4 positions de travail possibles.
- Timon placé à l'arrière et roues de grandes dimensions pour faciliter les déplacements.
- Crochet pivotant à 360°.
- Soupape de sécurité anti-surcharge.
- Commande de descente à vitesse contrôlée.
- Pompe hydraulique à deux vitesses.
- Roues en polyuréthane.

TECHNISCHE UND KONSTRUKTIVE ANGABEN

- Verchromte und schleifende Kolben, der eine große Zuverlässigkeit im Laufe der Zeit garantiert.
- Ausziehbare Arm in vier Arbeitspositionen.
- Mit beweglicher Deichsel und großen Rädern, um die maximale Wendigkeit zu sichern.
- 360° drehbare Haken.
- Angebaut Überlastventil gegen jeder Überlastung.
- Abstiegskontrolle mit einer kontrollierten Geschwindigkeit.
- Zweistufige hydraulische Pumpe.
- Mit Polyurethanrädern.

ART. 222/A

Supporto a bilanciere intercambiabile con il gancio.

Interchangeable with hook equalizer support.

Support à balancier interchangeable avec le crochet.

Tragschemel mit Ketten.

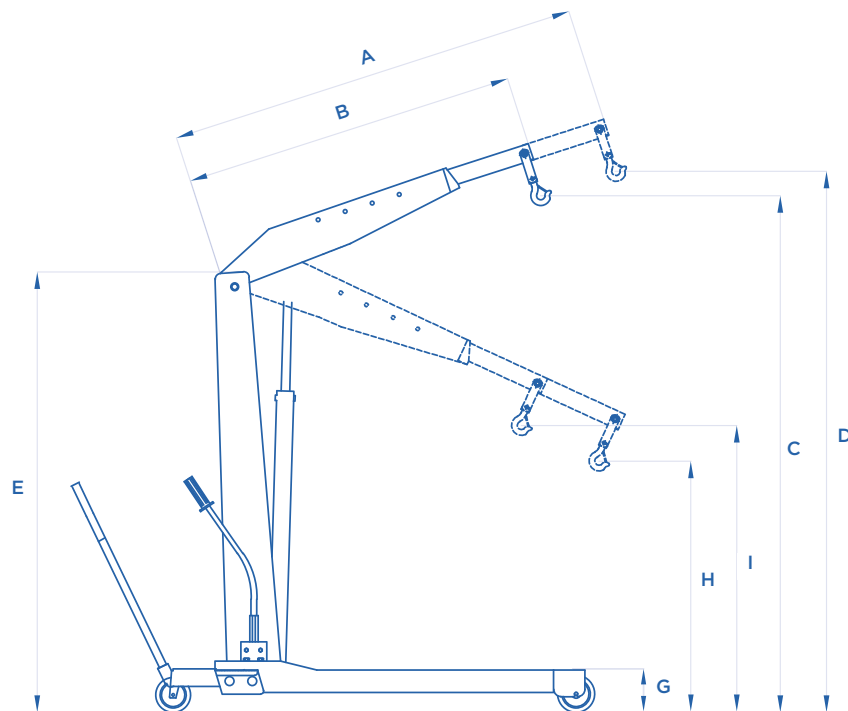

ART.

222

3000 Kg

2700 Kg

2550 Kg

2000 Kg

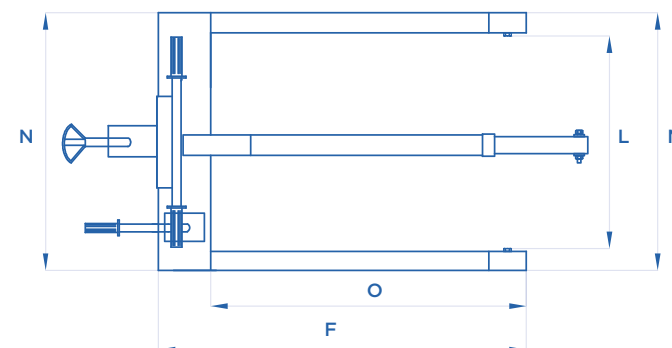

ART.		A mm	B mm	C mm	D mm	E mm	F mm	G mm	H mm	I mm	L mm	M mm	N mm	O mm	KG
222		2220	1600	3250	3800	2270	2350	340	370	750	1230	1460	1460	1860	520

ART. 222/A

OPTIONAL



3000 Kg



GRU IDRAULICHE A CARRELLO PIEGHEVOLI

FOLDING HYDRAULIC CRANES
GRUES HYDRAULIQUES PLIANTES
ZUSAMMENKLAPPBARE HYDRAULIKKRÄNE



ART. GP10/DE

TRACCIATO TECNICO COSTRUTTIVO

- Pieghevoli in pochi secondi, ingombro irrisorio in fase di riposizione.
- Lo stelo rettificato e cromato garantisce un'alta affidabilità nel tempo.
- Braccio allungabile in quattro posizioni di lavoro.
- Ruote posteriori girevoli per la massima manovrabilità.
- Gancio girevole a 360°.
- Valvola di protezione contro i sovraccarichi incorporata.
- Comando di discesa a velocità controllata.
- Pompa idraulica ad una velocità (GP05/S - GP10/S).
- Pompa idraulica a due velocità (GP05/DE - GP10/DE).
- Dotata di ruote in gomma (GP05/S - GP05/DE).
- Dotata di ruote in gomma e nylon (GP10/S - GP10/DE).

TECHNICAL AND STRUCTURAL LAY-OUT

- Foldable in just a few seconds and so small when stored.
- Ground chrome-plated rod for top reliability over time.
- Extendable arm in 4 working positions.
- Revolving rear wheels to move it easily.
- 360° revolving hook.
- Safety valve to avoid any possible overload.
- Descent control device with a controlled speed.
- One speed hydraulic pump (GP05/S - GP10/S).
- Two speed hydraulic pump (GP05/DE - GP10/DE).
- Rubber wheels (GP05/S - GP05/DE).
- Rubber and nylon wheels (GP10/S - GP10/DE).





RELEVÉ TECHNIQUE

- Se plie en quelques secondes et se range dans un mouchoir de poche.
- Vérin en acier spécial, rectifié et chromé, robuste et résistant.
- Flèche extensible: 4 positions de travail possibles.
- Roues arrière pivotantes pour faciliter les déplacements.
- Crochet pivotant à 360°.
- Soupape de sécurité anti-surcharge.
- Commande de descente à vitesse contrôlée.
- Pompe hydraulique à une vitesse (GP05/S - GP10/S).
- Pompe hydraulique à deux vitesses (GP05/DE - GP10/DE).
- Roues en caoutchouc (GP05/S - GP05/DE).
- Roues en caoutchouc et nylon (GP10/S - GP10/DE).

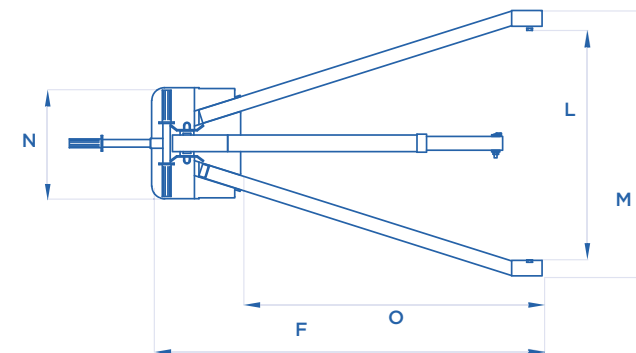
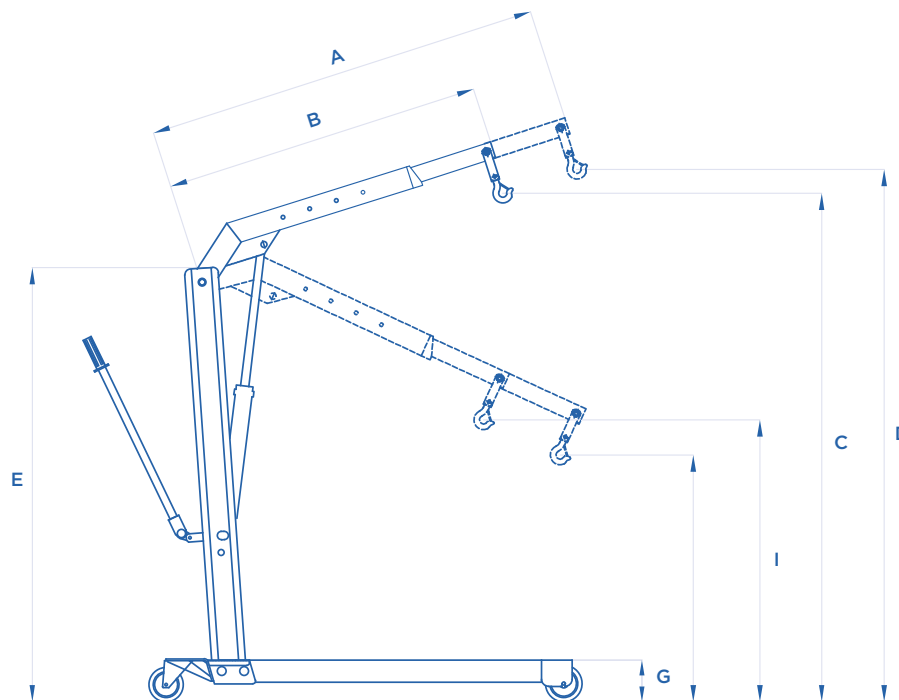
TECHNISCHE UND KONSTRUKTIVE ANGABEN

- In wenigen Sekunden zusammenklappbar und mit einem lächerlich Lagerfläche wenn es positioniert ist.
- Verchromte und schleifende Kolben, der eine große Zuverlässigkeit im Laufe der Zeit garantiert.
- Ausziehbarer Arm in vier Arbeitspositionen.
- Drehbare Hinterrädern, um die maximale Wendigkeit zu sichern.
- 360° drehbare Haken.
- Angebaut Überlastventil gegen jeder Überlastung.
- Abstiegskontrolle mit einer kontrollierten Geschwindigkeit.
- Einstufige hydraulische Pumpe (GP05/S - GP10/S).
- Zweistufige hydraulische Pumpe (GP05/DE - GP10/DE).
- Mit Gummirädern (GP05/S - GP05/DE).
- Mit Gummi- und Nylonrädern (GP10/S - GP10/DE).



ART.				
GP05/S GP05/DE	500 Kg	400 Kg	250 Kg	150 Kg
GP10/S GP10/DE	1000 Kg	800 Kg	500 Kg	300 Kg

ART.		A mm	B mm	C mm	D mm	E mm	F mm	G mm	H mm	I mm	L mm	M mm	N mm	O mm	KG
GP05/S GP05/DE	500 Kg	1300	1000	2130	2360	1570	1540	150	400	600	780	900	400	1160	80
GP10/S GP10/DE	1000 Kg	1470	1170	2180	2320	1700	1740	180	550	725	840	980	450	1325	122
GP10/DE	1000 Kg	1470	1170	2180	2320	1700	1740	180	550	725	840	980	450	1325	122

